

Maintaining A Difference: Delta-T – TD07

EFFECTIVE: 08.03.2015

SUPERSEDES: 03.1.2004

SOME ΔT APPLICATIONS FOR THE NEW TACO 00-VS CIRCULATOR

There are several ways to apply the new Taco 00-VS family of circulators. One of them is as a device capable of maintaining a preset temperature drop of 5 to 50 °F across a heat source or load.

The Taco 00-VS circulator can be specifically configured to monitor two temperature sensors and determine the temperature difference between them. It compares the measured temperature difference to a preset “target” temperature difference. The speed of the circulator is then adjusted up or down as necessary to eliminate any difference between the measure and target temperature difference.

The ability to change speed under varying load conditions can have a large effect on electrical energy consumption. Testing of 00-VS circulators shows that reducing the flow through the circulator by 50 percent reduces operating wattage approximately 50 percent. Considering the fact that the circulator will typically operate at reduced speeds over the majority of its service life, the savings in electrical energy consumption can be considerable.

This article discusses several applications for the 00-VS operated in the “delta T” mode. All these applications have the potential to significantly reduce power consumption without significantly effecting the system’s thermal performance.

DELTA-T LIMITING

Figure 1 shows how a 00-VS circulator can be configured to limit the temperature drop across a distribution system. This limiting ability can prevent large temperature drops from developing when a cool slab first receives heat input. Such high temperature differences can set up significant thermal expansion stresses in concrete that could cause cracks.

By limiting the temperature drop to a maximum value, the slab can be prevented from accepting heat faster than the heat source can provide it. To understand how this works, keep in mind that the rate of heat transfer to the load can be calculated using Formula 1.

$$\text{Formula 1: } Q = k \times f \times \Delta T$$

Where:

- Q = rate of heat transfer into the load (Btu/hr)
- f = the flow rate through the load (gpm)
- Δ T= temperature drop across the distribution system (°F)
- k = a number based on the fluid used
 - for water, k= 500
 - for a 30% glycol solution, k= 479
 - for a 50% glycol solution, k= 450

If the flow rate to the distribution system is known, and the temperature drop is limited to a specific value, the maximum rate of heat transfer can be calculated. For example, assume the flow rate of a 50% glycol solution through a snowmelting distribution system is known to be 10 gpm, and the temperature drop across the slab is limited to 20 °F by the 00-VS circulator. The maximum rate of heat transfer to the slab under these conditions can be calculated as:

$$Q = 450 \times 10 \times 20 = 90,000 \text{ Btu/Hr}$$

Figure 1

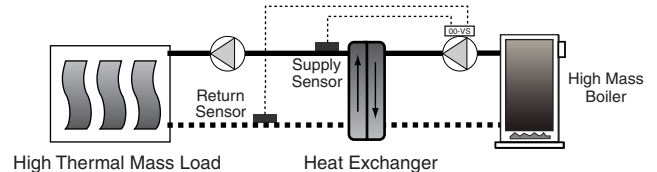

Product & Application Documents:

- PA05 – Variable Speed Setpoint “00” Circulator (00-VS)
- PA08 – Variable Speed Variable Voltage “00” Circulator (00-VV)

Operating Mode Documents:

- OM07 – Delta T (Temperature) & Setpoint with Delta T Max

Assuming the heat source was a conventional boiler with an output rating of at least 90,000 Btu/hr, limiting the temperature drop and thus the rate of heat acceptance by the slab would also ensure that the latter could not extract heat from the circulating fluid faster than the heat could be generated by the boiler.

TEMPERATURE RISE ACROSS BOILERS

One of the primary motivations for variable speed pumping is to reduce electrical energy consumption without sacrificing thermal performance. One excellent opportunity for doing so is controlling the flow rate through boilers in a primary / secondary as shown in Figure 2.

Often times, the circulators on individual boilers are oversized and consume more electrical energy than necessary. Cast-iron boilers are usually capable of operating with temperature rises significantly higher than what an oversized circulator allows. Temperature rises of 30 to 40 °F are possible without significantly effecting thermal performance.

Using a 00-VS circulator to maintain a set temperature rise on such boilers minimizes the electrical consumption of the boiler circulators and still provides proper flow through each boiler. The acceptable maximum temperature rise for low mass boilers is less than for cast-iron boilers. Designers should always verify the acceptable maximum temperature rise with the boiler manufacturer prior to setting the delta-T of the 00-VS circulator.

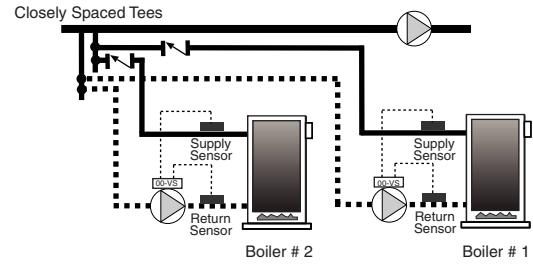

Figure 2

PRIMARY LOOP CIRCULATOR

Another excellent application for the 00-VS circulator is regulating the temperature drop around a series primary loop in a primary / secondary piping system. An example of this application is shown in Figure 3.

When one or more of the secondary circuits turns off, the 00-VS circulator reduces speed to maintain a fixed temperature drop around the primary loop under the reduced loading. This scenario allows the designer to select the circulator based on a specified temperature drop. Higher temperature drops of 30 to 40 °F will reduce the necessary primary loop flow and possibly decrease the piping size, circulator size, and life-cycle operating cost of the primary circulator. This is especially relevant since the primary circulator needs to operate whenever any of the secondary loads are on, and thus usually sees a higher duty cycle than other circulators in the system.

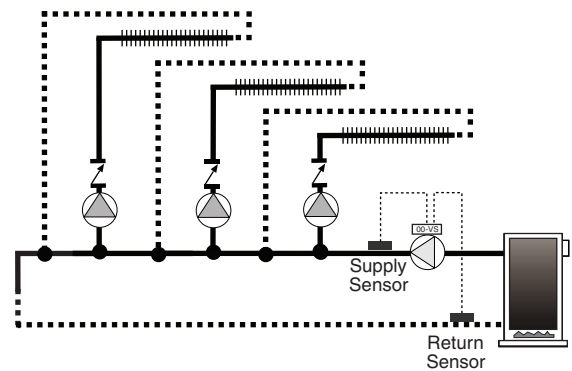

Figure 3

When a conventional boiler is used as the heat source, the combination of boiler supply temperature and primary loop temperature drop must not allow the boiler inlet temperature to be low enough to create sustained flue gas condensation. A suggested minimum boiler inlet temperature of 130 °F is suggested in these cases. A lower inlet temperature may be possible depending on the specific boiler used. Again, check with the boiler manufacturer for a minimum recommended inlet fluid temperature.

The primary loop flow rate needed under design load conditions can be calculated using Formula 2.

$$\text{Formula 2: } F = Q / (k \times \Delta T)$$

Where:

- Q = rate of heat output of boiler system supplying primary loop (Btu/hr)
- f = required primary loop flow rate (gpm)
- Δ T = temperature drop to be maintained around the primary loop (°F)
- k = a number based on the fluid used
 - for water, k= 500
 - for a 30% glycol solution, k= 479
 - for a 50% glycol solution, k= 450

Once the primary loop flow rate is determined, a pipe size can be selected based on maintaining a flow velocity in the range of 4 to 5 feet / minute. The head loss of the primary loop can then be estimated and the circulator selected based on the required operating point.

SYSTEMS WITH ZONE VALVES

Another potential application for the 00-VS circulator is maintaining a fixed temperature drop across a distribution system containing a number of independently controlled zone valves as shown in Figure 4.

The distribution system would be designed for a set temperature drop at design load conditions. When a zone valve closes the load instantly drops. This causes the temperature drop between the supply and return side of the distribution system to decrease. The 00-VS circulator senses this decrease and reduces its speed to maintain a constant temperature drop. This not only saves electrical energy, it also reduces the chances of both high differential pressure across the circulator and flow noise when only one or two zones are operating.

The 00-VS circulator could also be used in combination with panel radiators connected to a home-run type distribution system as shown in Figure 5.

As the thermostatic radiator valves reduce flow through individual radiators, the 00-VS circulator would sense the decreasing load and reduce the speed of the circulator accordingly.

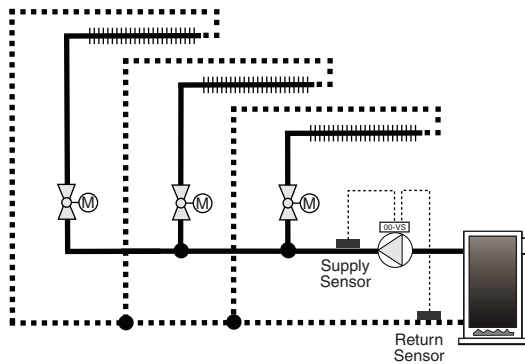

Figure 4

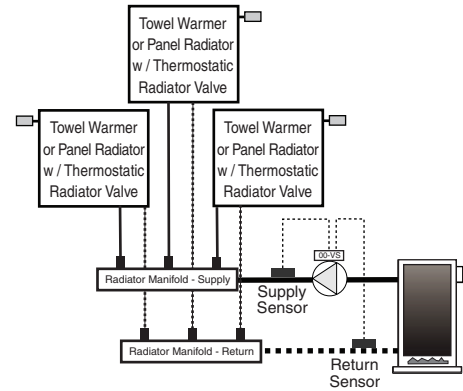

Figure 5

DELTA-T CONTROL IN GHSP SYSTEMS

Closed-loop ground source heat pumps (as shown in Figure 6) require simultaneous flow through both their evaporator and condenser whenever they are operating. As the loads on the heat pump change, so does the temperature drop across the evaporator and the temperature rise across the condenser. Decreasing loads produce decreased temperature changes when a constant speed circulator is used. Although reduced temperature changes are not usually a problem from the standpoint of thermal performance; they do allow the circulators to operate at higher power levels than necessary.

When a 00-VS circulator is used the temperature drop across the evaporator and the temperature rise across the condenser can be maintained to preset values. Typical values for these delta-Ts are in the range of 10 to 15 °F. However, the maximum acceptable temperature changes across the evaporator and condenser of a specific heat pump should be verified with the heat pump manufacturer. The use of appropriately sized 00-VS circulators on both the evaporator and condenser will result in less electrical consumption by the circulators and higher overall system efficiency.

Temperature rise across solar collectors: Minimizing the electrical consumption needed to circulate fluid through solar energy collectors is important in achieving high overall system efficiency. The use of a properly sized 00-VS circulator as the collector pump in a closed-loop anti-freeze type solar system allows the collector flow rate to be adjusted to match the current solar intensity. This will reduce electrical consumption under partial sun conditions.

SUMMARY

As you can see, the versatility of Taco 00-VS series circulators provides creative system designers the opportunity to improve system performance while at the same time reducing operating cost. They are another example of leading edge hydronic heating technology brought to you by Taco.

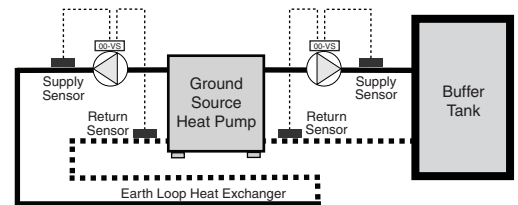

Figure 6

 **TACO** Comfort  Solutions™ A Taco Group Company

Taco, Inc., 1160 Cranston Street, Cranston, RI 02920 | Tel: (401) 942-8000 | FAX: (401) 942-2360

Taco (Canada), Ltd., 8450 Lawson Road, Suite #3, Milton, Ontario L9T 0J8 | Tel: (905) 564-9422 | FAX: (905) 564-9436

Visit our web site: www.TacoComfort.com | Printed in USA | ©2015 Taco, Inc.

