

iSeries-R (Outdoor Reset) Mixing Valve – PA04

EFFECTIVE: 08.03.2015

SUPERSEDES: 08.15.2005

OVERVIEW

iSeries-R (Outdoor Reset) Mixing Valve

Use the Taco Outdoor Reset iSeries Mixing Valves instead of a conventional injection system. The iSeries-R is a microprocessor-based valve designed to regulate the supply water temperature to a heating system, based on a reset ratio, by modulating the position of an iSeries Mixing Valve, so that the heat supplied to the building or zone equals the heat lost by the building. With a full featured outdoor reset control built right into the actuator, there is no need for an externally mounted reset control or expensive control valve. The iSeries-R can also be set up to do zone-by-zone outdoor reset, providing optimal comfort control for every zone.

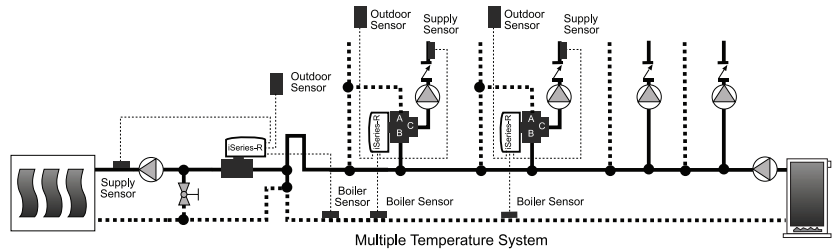

The direct drive actuator modulates a 2-way, 3-way or 4-way valve that injects different rates of hot water, supplying virtually any water temperature to the heating system. Working off an adjustable reset ratio, the valve's maximum and minimum system supply temperatures can be adjusted to support all types of jobs, including staple-up radiant floors that require a higher starting temperature. The iSeries-R includes an adjustable boiler protection function which prevents low water temperatures from returning to the boiler. With a multi-status LED indicator light, plug-in wiring connections and an easy to remove actuator, the installation could not be easier.

The direct drive actuator modulates a 2-way, 3-way or 4-way valve that injects different rates of hot water, supplying virtually any water temperature to the heating system. Working off an adjustable reset ratio, the valve's maximum and minimum system supply temperatures can be adjusted to support all types of jobs, including staple-up radiant floors that require a higher starting temperature. The iSeries-R includes an adjustable boiler protection function which prevents low water temperatures from returning to the boiler. With a multi-status LED indicator light, plug-in wiring connections and an easy to remove actuator, the installation could not be easier.

CONTROL STRATEGY

Outdoor Reset

In order to properly control a hot water heating system, the heat supplied to the building must equal the heat lost by the building.

- The heat supplied to the building is directly proportional to the temperature of the water and the surface area of the heating element. The higher the temperature of the water flowing through the heating terminal, the higher the heat output.
- The heat lost from a building is dependent on the outdoor temperature. As the outdoor temperature drops, the building heat loss increases.

These two facts lead to the concept of outdoor reset, based on a reset ratio, which increases the supply water temperature as the outdoor temperature drops. Using this approach, the heat lost from the building is matched by the heat provided by the terminal units, therefore providing more comfort and energy savings.

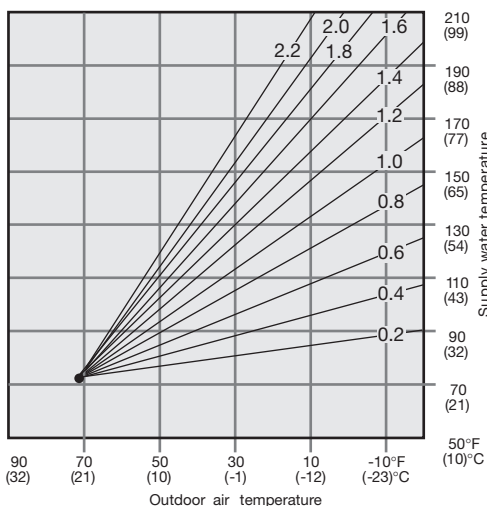

Features:

- 2-way injection or 3-way and 4-way mixing
- Operates off constant power or relay end switch
- Ball valve design, high Cv
- Manual operation button
- Solid state microprocessor design
- Compact
- Easy, one-handed actuator removal
- 125 PSI shutoff pressure
- Plug-in low voltage connections
- Multi-status LED indicator light
- Fail safe mode
- Sensors included
- Selectable maximum supply temperature (110°F, 130°F, 150°F or OFF)
- Selectable minimum supply temperature (85°F, when maximum supply temperature is set to 150°F or OFF)
- Adjustable minimum boiler return temperature (120°F, 135°F or OFF)
- Warm weather shutdown (70°F or OFF).
- Adjustable heating curve (0.2 to 2.2)

Reset Ratio

The Reset Ratio sets the relationship between outdoor temperature and supply water temperature. It determines the amount the supply water temperature is raised for every 1 degree outdoor temperature drop. For example, if a Reset Ratio of 1.2 is selected, the supply water temperature is increased by 1.2 degrees of every 1 degree of outdoor temperature drop.

DESIGN

When using an iSeries-R Mixing Valve, the following piping requirements must be considered for proper operation.

1. In order to hydraulically isolate the boiler loop from the injection or system loop primary/secondary piping must be used. There must be no more than 4 pipe diameters between the tees in the boiler loop (Note 1).
2. There must be at least 6 pipe diameters of straight pipe on either side of the tees (Note 2) in order to prevent the momentum of water in the boiler loop from pushing flow through the injection loop.
3. There should be a minimum of 1 foot drop on the return pipe of the injection loop, in order to create a thermal trap (Note 3) and prevent unwanted heat transfer.
4. When using a 2-way iSeries-R Mixing Valve, a balancing valve must be located between the tees in the system loop, in order to provide a pressure drop to induce flow through the mixing loop.

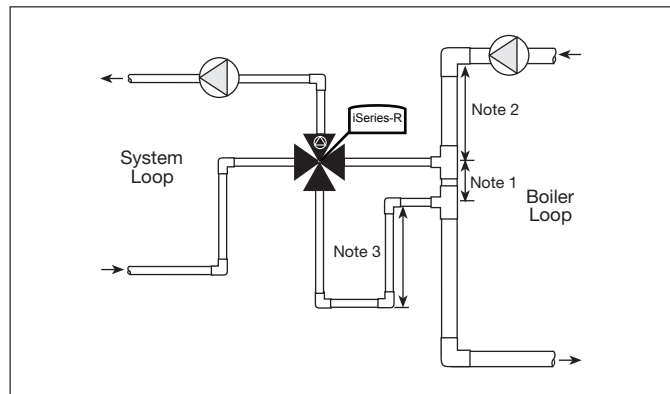
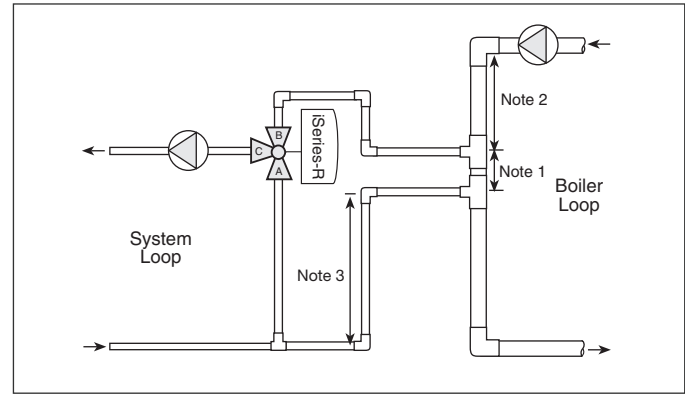
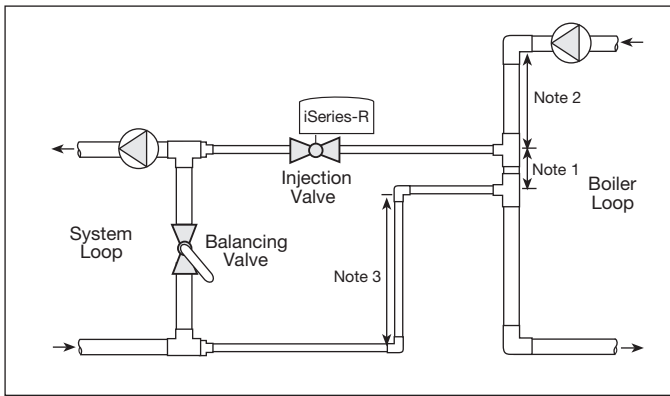

VALVE SIZING AND SELECTION

2-way iSeries-R Mixing Valve Selection

In order to properly size the 2-way iSeries-R Mixing Valve, follow the design procedure below:

- 1) Determine the design radiant heating load.
- 2) Determine the design boiler supply temperature.

3) Determine the radiant system return temperature which is based on the design temperature drop across the radiant system.

4) Determine the design injection flow rate using the following equation:

$$\text{Eq. 1: Design Injection Flow Rate (US GPM)} = \frac{\text{Design Radiant Heating Load (BTU/hr)}}{500 \times (\text{Boiler Supply} - \text{Radiant System Return})}$$

5) From the 2-way Cv chart below, select the valve size with the closest Cv value to the injection flow rate calculated in step 4. Do not size the 2-way iSeries Mixing Valve based solely on pipe size.

iSeries: 2-way Cv	
Size	Cv
1/2"	4.9
3/4"	10.3
1"	8.9

3-way iSeries-R Mixing Valve Selection

Select the 3-way iSeries-R Mixing Valve based on the 3-way Pressure Drop chart below.

Flow	iSeries: 3-way Valve Pressure Drop					
	1/2" (Cv = 1.5)		3/4" (Cv = 3.3)		1" (Cv = 3.0)	
GPM	PSI	Ft. Head	PSI	Ft. Head	PSI	Ft. Head
1/2	0.11	0.26	0.02	0.05	0.03	0.06
1	0.44	1.03	0.09	0.21	0.11	0.26
1 1/2	1.00	2.31	0.21	0.48	0.25	0.58
2	1.78	4.11	0.37	0.85	0.44	1.03
4	—	—	1.47	3.39	1.78	4.11
6	—	—	3.31	7.64	4.00	9.24
8	—	—	5.88	13.58	—	—

4-way iSeries-R Mixing Valve Selection

Select the 4-way iSeries-R Mixing Valve based on the 4-way Pressure Drop chart below:

Flow	iSeries: 4-way Valve Pressure Drop					
	3/4" (Cv = 7.0)		1" (Cv = 9.3)		1 1/4" (Cv = 17.5)	
GPM	PSI	Ft. Head	PSI	Ft. Head	PSI	Ft. Head
1/2	0.01	0.01	0.00	0.01	0.00	0.00
1	0.02	0.05	0.01	0.03	0.00	0.01
2	0.08	0.19	0.05	0.11	0.01	0.03
4	0.33	0.75	0.18	0.43	0.05	0.12
6	0.73	1.69	0.42	0.96	0.12	0.27
8	1.31	3.01	0.74	1.71	0.21	0.48
10	2.04	4.71	1.16	2.67	0.33	0.75
12	2.94	6.79	1.66	3.84	0.47	1.08
14	4.00	9.24	2.28	5.27	0.64	1.48
16	—	—	2.96	6.84	0.84	1.93
18	—	—	3.76	8.70	1.06	2.44
20	—	—	—	—	2.30	5.31

OPERATION

iSeries-R Power Up and Heat Request

Whenever the iSeries-R is powered up, the LED turns on and the control starts operation. The power to the iSeries-R may be switched through an end switch (e.g. Taco ZVC/SR style zone control), a thermostat for intermittent operation, or a power source (24 vac) may be connected directly to the iSeries-R for continuous operation.

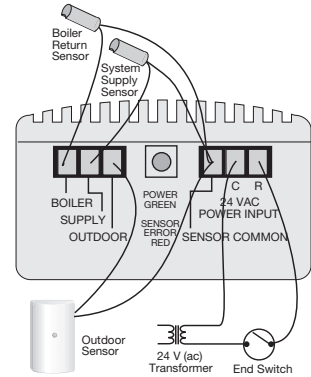

Reset Ratio

Once the iSeries-R is powered up, it provides outdoor reset at the supply sensor location. The iSeries-R targets a supply temperature based on the outdoor temperature measured and the Reset Ratio dial setting. The Reset Ratio is set using the following formula:

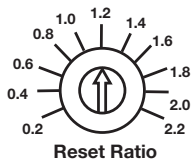

$$\text{Reset Ratio} = \frac{\text{Design Supply Temperature} - 72^{\circ}\text{F}}{72^{\circ}\text{F} - \text{Design Outdoor Temperature}}$$

Maximum/Minimum System Supply Temperature (DIP switch 1 & 2)

The iSeries-R has a maximum supply function used to set a maximum supply water target temperature. This function helps to protect system components, such as floor coverings, by preventing excessive water temperatures. The maximum target temperature is selected using DIP switches 1 & 2.

When selecting a maximum supply target temperature of 150°F, the iSeries-R also enables a minimum supply target temperature of 85°F. This function is typically used in staple up radiant floor heating applications, in order to ensure enough heat delivery during mild outdoor temperatures.

If the actual supply water temperature approaches the maximum or minimum system supply, the iSeries-R modulates the valve down and the green LED flashes rapidly (reduced output).

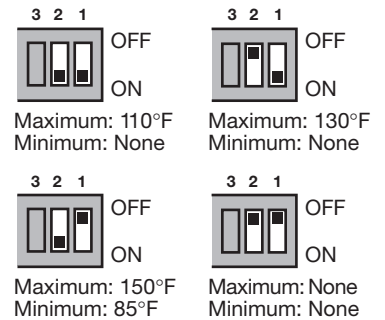

Minimum Boiler Return Temperature (DIP switch 3)

The iSeries-R includes a boiler protection function which prevents low temperatures back to the boiler. Whenever the boiler sensor is installed, the iSeries-R monitors the boiler return temperature and modulates the valve down when the return temperature is near the minimum setting. The minimum setting is selected via DIP switch 3. When the switch is turned on, the minimum temperature is set to 120°F and when the DIP is turned off the minimum temperature is 135°F.

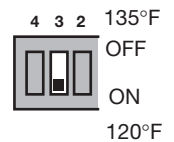

When using low temperature boilers such as condensing or electric, the boiler minimum temperature may be disabled by powering up the control without a boiler return sensor. Whenever the iSeries-R is being modulated towards the closed position to protect the boiler, the green LED flashes rapidly (reduced output).

Warm Weather Shut Down (WWSD) (DIP switch 4)

When the outdoor temperature is warmer than 70°F, the iSeries-R closes. The green LED then slowly flashes during warm weather shut down. This function may be turned on by setting the DIP switch 4 to the on position.

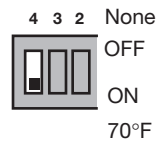

INSTALLATION

2-way Installation

For installations where boiler protection is **NOT** required, the boiler sensor does not need to be installed.

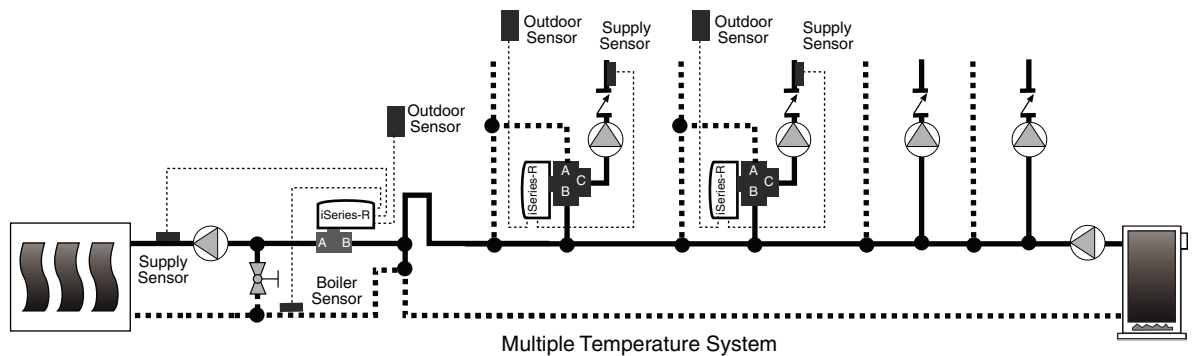
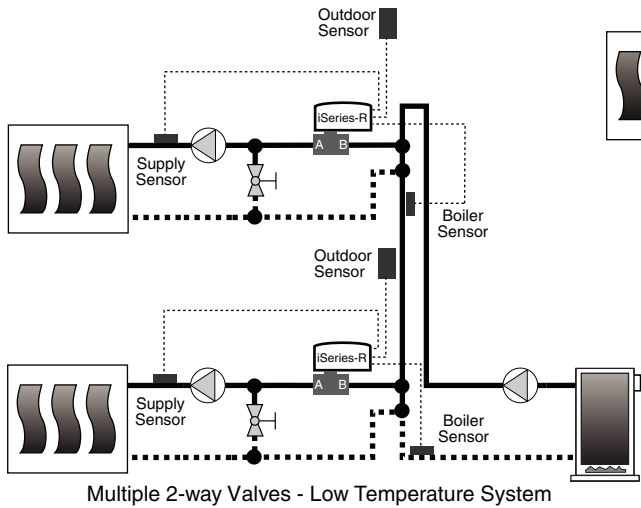
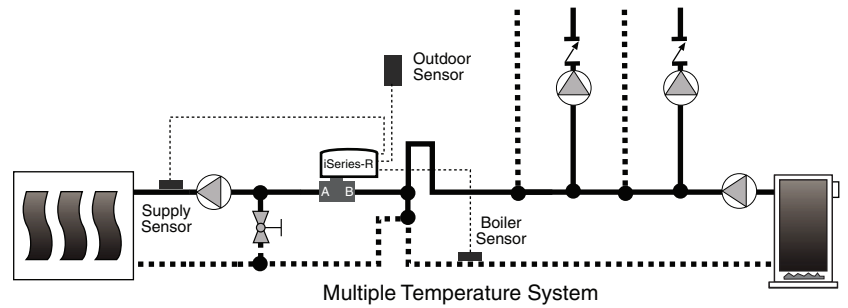
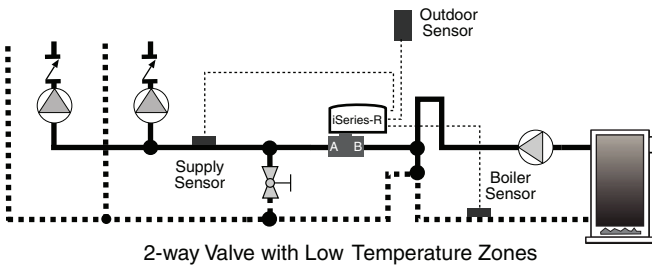
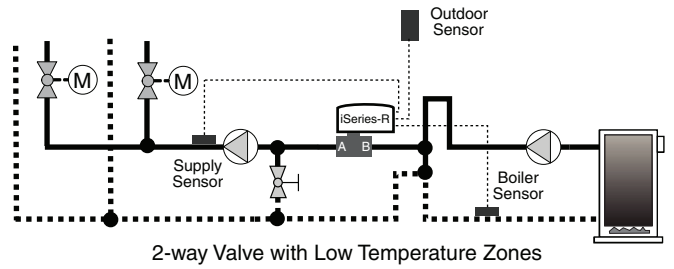
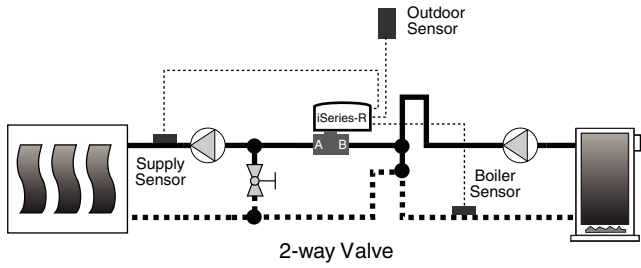

3-way Installation

For installations where boiler protection is **NOT** required, the boiler sensor does not need to be installed.

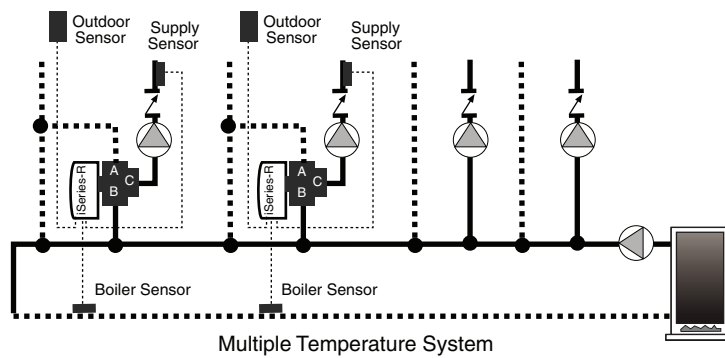
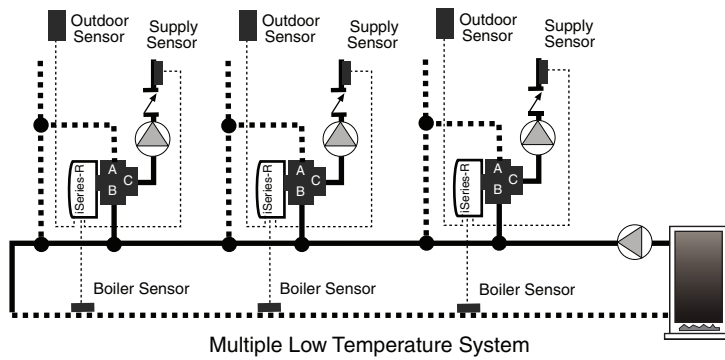
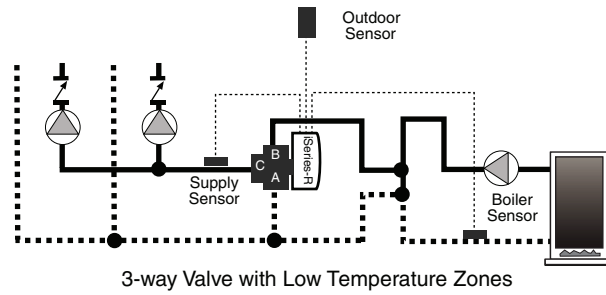
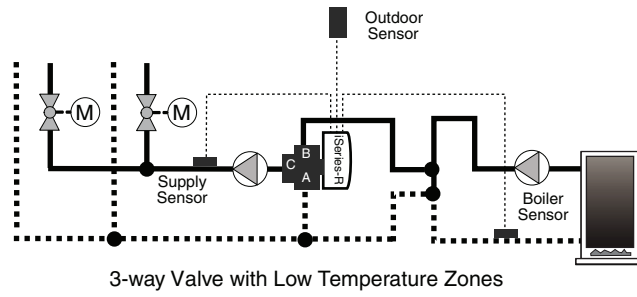
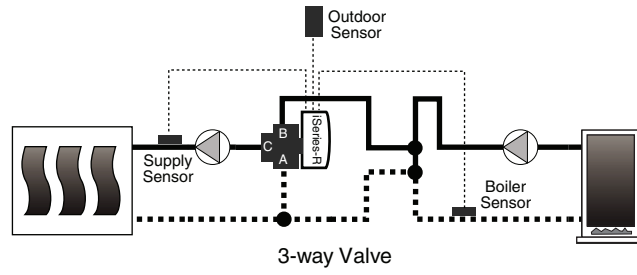

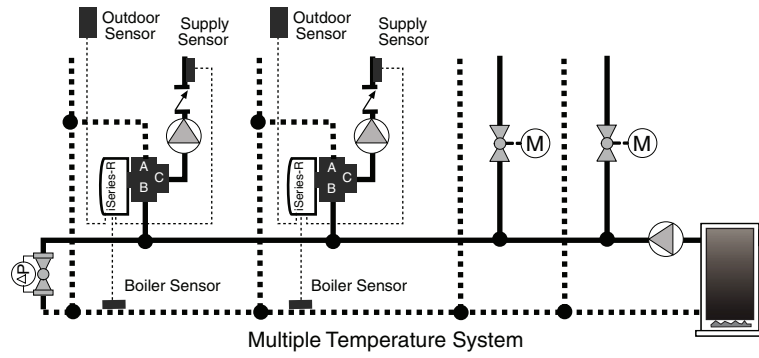

Multiple Temperature System

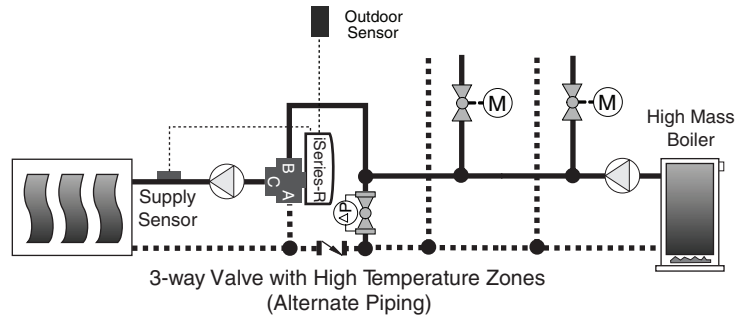

3-way Valve with High Temperature Zones
(Alternate Piping)

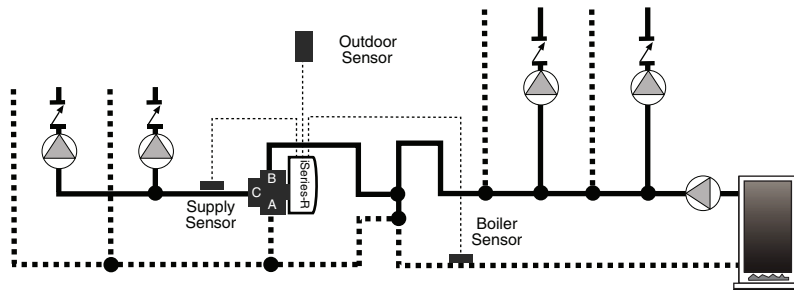

Multiple Temperature System

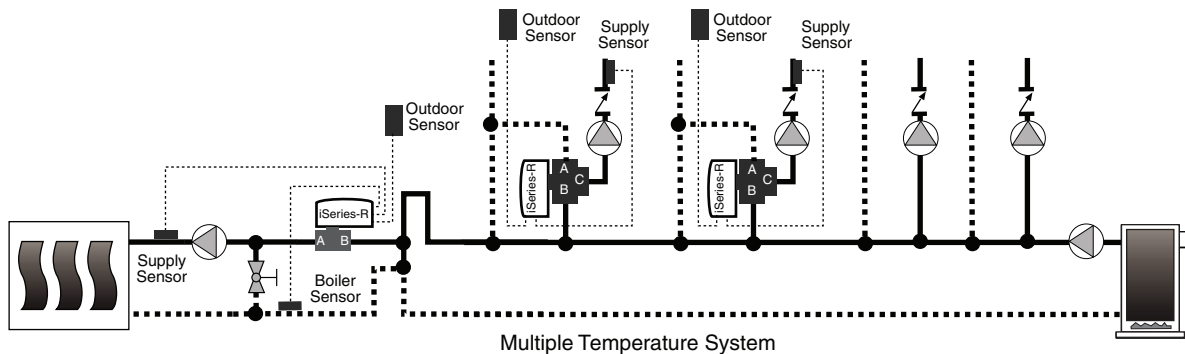

Multiple Temperature System

4-way Installation

For installations where boiler protection is **NOT** required, the boiler sensor does not need to be installed.

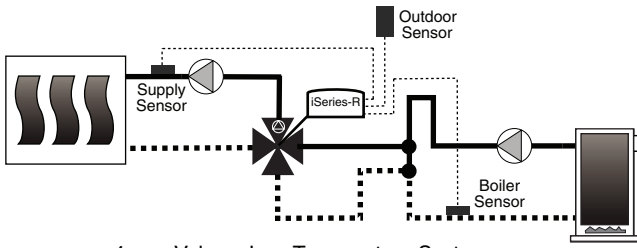

4-way Valve – Low Temperature System

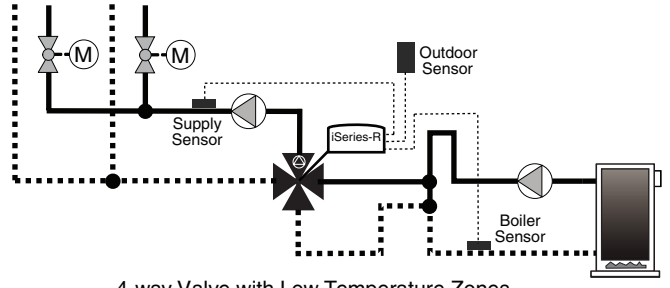

4-way Valve with Low Temperature Zones

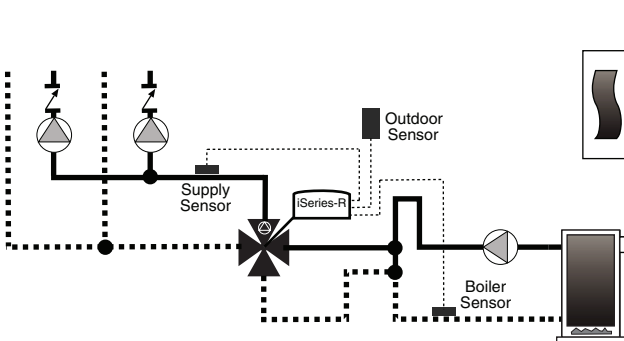

4-way Valve with Low Temperature Zones

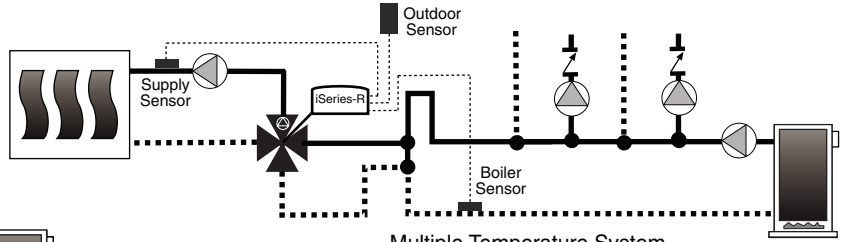

Multiple Temperature System

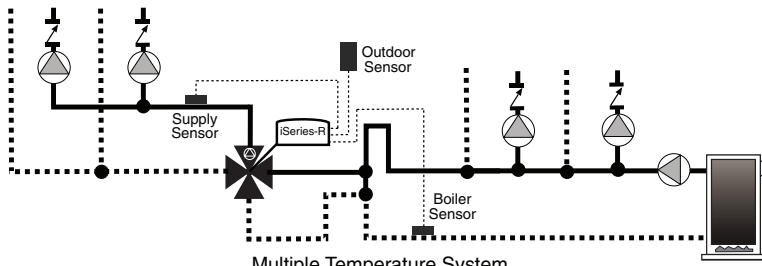

Multiple Temperature System

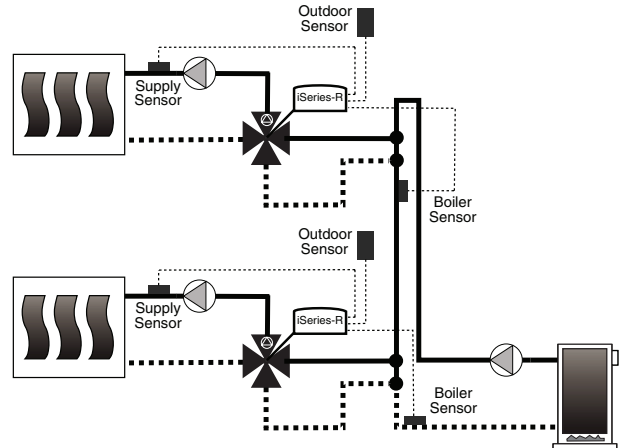

Multiple 4-way Valves - Low Temperature System

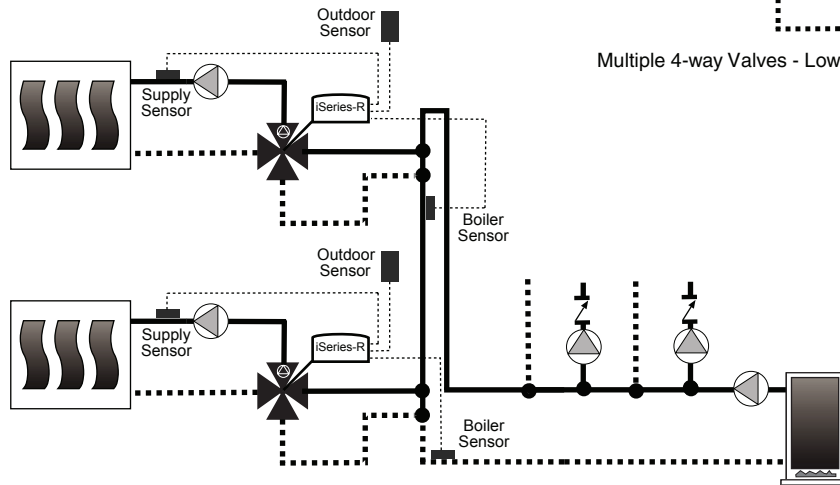

Multiple Temperature System

Taco Comfort Solutions™ A Taco Group Company

Taco, Inc., 1160 Cranston Street, Cranston, RI 02920 | Tel: (401) 942-8000 | FAX: (401) 942-2360

Taco (Canada), Ltd., 8450 Lawson Road, Suite #3, Milton, Ontario L9T 0J8 | Tel: (905) 564-9422 | FAX: (905) 564-9436

Visit our web site: www.TacoComfort.com | Printed in USA | ©2015 Taco, Inc.

